

1.10 Hlavní směry

```
> restart;
> with(LinearAlgebra):
> with(linalg):
> with(plots):
> X:=Vector[row]([x,y,z,1]);
X := [x, y, z, 1]
```

Matice kvadriky:

```
> K:=Matrix(a,1..4,1..4,shape=symmetric);
K := 
$$\begin{bmatrix} a(1,1) & a(1,2) & a(1,3) & a(1,4) \\ a(1,2) & a(2,2) & a(2,3) & a(2,4) \\ a(1,3) & a(2,3) & a(3,3) & a(3,4) \\ a(1,4) & a(2,4) & a(3,4) & a(4,4) \end{bmatrix}$$

```

Rovnice kvadriky:

```
> Kv:=sort(expand(X.K.Transpose(X)),[x,y,z])=0;
Kv := 
$$a(1,1)x^2 + 2a(1,2)xy + 2a(1,3)xz + a(2,2)y^2 + 2a(2,3)yz + a(3,3)z^2 + 2a(1,4)x + 2a(2,4)y + 2a(3,4)z + a(4,4) = 0$$

```

Parametrické rovnice tečny se směrem $sm = [u, v, w]$ a s bodem dotyku $M = [m, n, p]$

```
> Tecna:=[x=m+t*u,y=n+t*v,z=p+t*w];
Tecna := [x = m + t u, y = n + t v, z = p + t w]
> Kv0:=simplify(eval(Kv,[x=m,y=n,z=p]));
Kv0 := 
$$a(1,1)m^2 + 2a(1,2)mn + 2a(1,3)mp + a(2,2)n^2 + 2a(2,3)np + a(3,3)p^2 + 2a(1,4)m + 2a(2,4)n + 2a(3,4)p + a(4,4) = 0$$

> Kv1:=simplify(eval(Kv,Tecna));
Kv1 := 
$$2a(1,1)m t u + 2a(1,2)m t v + 2a(1,2)t u n + 2a(1,2)t^2 u v + 2a(1,3)m t w + 2a(1,3)t u p + 2a(1,3)t^2 u w + 2a(2,2)n t v + 2a(2,3)n t w + 2a(2,3)t v p + 2a(2,3)t^2 v w + 2a(3,3)p t w + a(1,1)m^2 + a(2,2)n^2 + a(3,3)p^2 + 2a(1,4)m + 2a(2,4)n + 2a(3,4)p + a(4,4) + a(1,1)t^2 u^2 + a(2,2)t^2 v^2 + a(3,3)t^2 w^2 + 2a(1,4)t u + 2a(2,4)t v + 2a(3,4)t w + 2a(1,2)m n + 2a(1,3)m p + 2a(2,3)n p = 0$$

> A:=coeff(lhs(Kv1),t^2);
A := 
$$2a(1,2)u v + 2a(1,3)u w + 2a(2,3)v w + a(1,1)u^2 + a(2,2)v^2 + a(3,3)w^2$$

> B:=1/2*coeff(lhs(Kv1),t);
B := 
$$a(1,1)m u + a(1,2)m v + a(1,2)u n + a(1,3)m w + a(1,3)u p + a(2,2)n v$$

```

```

+ a(2, 3) n w + a(2, 3) v p + a(3, 3) p w + a(1, 4) u + a(2, 4) v + a(3, 4) w
> C:=sort(coeff(lhs(Kv1),t,0),[r,s,u]);
C := a(1, 1) m2 + 2 a(1, 2) m n + 2 a(1, 3) m p + a(2, 2) n2 + 2 a(2, 3) n p + a(3, 3) p2
+ 2 a(1, 4) m + 2 a(2, 4) n + 2 a(3, 4) p + a(4, 4)
> B1:=collect(B,[u,v,w]);
B1 := (a(1, 1) m + a(1, 3) p + a(1, 4) + a(1, 2) n) u
+ (a(1, 2) m + a(2, 2) n + a(2, 4) + a(2, 3) p) v
+ (a(3, 3) p + a(2, 3) n + a(1, 3) m + a(3, 4)) w
> a1:=sort(coeff(B1,u),[m,n,p]); b1:=sort(coeff(B1,v),[m,n,p]);
c1:=sort(coeff(B1,w),[m,n,p]);
d1:=sort(coeff(coeff(coeff(B1,u,0),v,0),w,0),[m,n,p]);
a1 := a(1, 1) m + a(1, 2) n + a(1, 3) p + a(1, 4)
b1 := a(1, 2) m + a(2, 2) n + a(2, 3) p + a(2, 4)
c1 := a(1, 3) m + a(2, 3) n + a(3, 3) p + a(3, 4)
d1 := 0
> B2:=collect(B,[m,n,p]);
B2 := (a(1, 1) u + a(1, 2) v + a(1, 3) w) m + (a(1, 2) u + a(2, 2) v + a(2, 3) w) n
+ (a(2, 3) v + a(3, 3) w + a(1, 3) u) p + a(3, 4) w + a(1, 4) u + a(2, 4) v
> ra:=sort(coeff(B2,m),[u,v,w]); rb:=sort(coeff(B2,n),[u,v,w]);
rc:=sort(coeff(B2,p),[u,v,w]);
rd:=sort(coeff(coeff(coeff(B2,m,0),n,0),p,0),[u,v,w]);
ra := a(1, 1) u + a(1, 2) v + a(1, 3) w
rb := a(1, 2) u + a(2, 2) v + a(2, 3) w
rc := a(1, 3) u + a(2, 3) v + a(3, 3) w
rd := a(1, 4) u + a(2, 4) v + a(3, 4) w
> U:=Vector[row]([u,v,w,0]);
U := [u, v, w, 0]
> PrumerR:=collect(expand(evalm(U*K&*Transpose(X))),[x,y,z])=0;
PrumerR := (a(1, 1) u + a(1, 2) v + a(1, 3) w) x + (a(1, 2) u + a(2, 2) v + a(2, 3) w) y
+ (a(1, 3) u + a(2, 3) v + a(3, 3) w) z + a(1, 4) u + a(2, 4) v + a(3, 4) w = 0
> n:=[coeff(lhs(PrumerR),x),coeff(lhs(PrumerR),y),coeff(lhs(PrumerR),z)];
n := [a(1, 1) u + a(1, 2) v + a(1, 3) w, a(1, 2) u + a(2, 2) v + a(2, 3) w,
a(1, 3) u + a(2, 3) v + a(3, 3) w]

```

Příklad: Hlavní směry a roviny kvadriky $x^2 + 4y^2 + 16z^2 - 144 = 0$.

```

> kv:=x^2+4*y^2+16*z^2-144=0;
kv := x2 + 4 y2 + 16 z2 - 144 = 0
> a(1,1):=coeff(lhs(kv),x^2); a(2,2):=coeff(lhs(kv),y^2);
a(3,3):=coeff(lhs(kv),z^2);
a(1,2):=1/2*coeff(coeff(lhs(kv),x),y);

```

```

a(1,3):=1/2*coeff(coeff(lhs(kv),x),z);
a(1,4):=1/2*coeff(coeff(coeff(lhs(kv),x,1),y,0),z,0);
a(2,3):=1/2*coeff(coeff(lhs(kv),y,1),z);
a(2,4):=1/2*coeff(coeff(coeff(lhs(kv),y,1),x,0),z,0);
a(3,4):=1/2*coeff(coeff(coeff(lhs(kv),z,1),y,0),x,0);
a(4,4):=coeff(coeff(coeff(lhs(kv),x,0),y,0),z,0);

```

```
a(1,1) := 1
```

```
a(2,2) := 4
```

```
a(3,3) := 16
```

```
a(1,2) := 0
```

```
a(1,3) := 0
```

```
a(1,4) := 0
```

```
a(2,3) := 0
```

```
a(2,4) := 0
```

```
a(3,4) := 0
```

```
a(4,4) := -144
```

```
> K;
```

$$\begin{bmatrix} 1 & 0 & 0 & 0 \\ 0 & 4 & 0 & 0 \\ 0 & 0 & 16 & 0 \\ 0 & 0 & 0 & -144 \end{bmatrix}$$

```
> n;
```

```
[u, 4 v, 16 w]
```

```
> uv:=[u,v,w];
```

```
uv := [u, v, w]
```

```
> r:=evalm(n-lambda*uv);
```

```
r := [u - λ u, 4 v - λ v, 16 w - λ w]
```

```
> ChM:=linalg[genmatrix]([r[1],r[2],r[3]],[u,v,w]);
```

$$ChM := \begin{bmatrix} 1-\lambda & 0 & 0 \\ 0 & 4-\lambda & 0 \\ 0 & 0 & 16-\lambda \end{bmatrix}$$

```
> ChR:=linalg[det](ChM)=0;
```

```
ChR := (1 - λ) (4 - λ) (16 - λ) = 0
```

```
> collect(ChR,[lambda^3,lambda^2,lambda]);
```

```
64 - λ3 + 21 λ2 - 84 λ = 0
```

```
> I1:=coeff(lhs(ChR),lambda,2);
```

```
I1 := 21
```

```
> I2:=coeff(lhs(ChR),lambda,1);
```

```
I2 := -84
```

```
> A44:=coeff(lhs(ChR),lambda,0);
```

```
A44 := 64
```

```
> Delta:=linalg[det](K);
```



```

> ug1:=plots[arrow]([-5, -5, 10], vector(Smer1), width=[0.2,
  relative],length=5, head_length=[0.2, relative], color=green):
> Smer1g:=plottools[arrow]([-5, -5, 8], vector(6*Smer1), 0.5, 1,
  0.2, cylindrical_arrow,color=coll):
> Kuz1g:=spacecurve(Kuz1,x=-15..15,thickness=3,numpoints=1000,colo
  r=yellow):
  Kuz2g:=spacecurve(Kuz2,x=-15..15,thickness=3,numpoints=1000,colo
  r=yellow):
> display(kvg,PrumerR1g,Smer1g,Kuz1g,Kuz2g,axes=frame,scaling=cons
  trained);

```

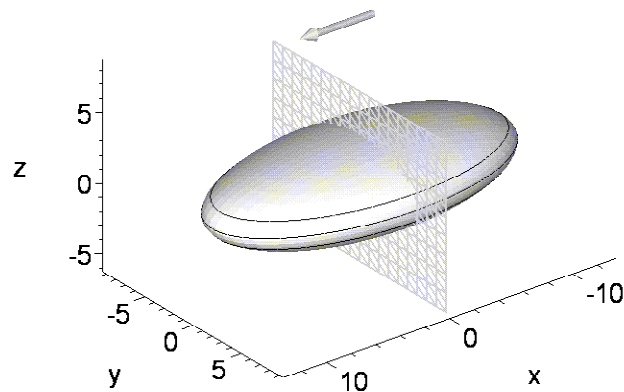

```

> Smer2:=eval(hs2,v=1);
      Smer2 := [0, 1, 0]
> PrumerR2:=eval(PrumerR,[u=Smer2[1],v=Smer2[2],w=Smer2[3]]);
      PrumerR2 := 4 y = 0
> kv;
      x2 + 4 y2 + 16 z2 - 144 = 0
> {kv,PrumerR2};
      {4 y = 0, x2 + 4 y2 + 16 z2 - 144 = 0}
> res2:=solve({kv,PrumerR2},{x,y,z});
      res2 := {x = 4 RootOf(_Z2 + z2 - 9, label = _L3), y = 0, z = z}
> Kuz:=allvalues(res2);
      Kuz := {x = 4√(9 - z2), y = 0, z = z}, {x = -4√(9 - z2), y = 0, z = z}
> Kuz1:=eval([x,y,z],Kuz[1]); Kuz2:=eval([x,y,z],Kuz[2]);

```

$$Kuz1 := [4\sqrt{9-z^2}, 0, z]$$

$$Kuz2 := [-4\sqrt{9-z^2}, 0, z]$$

```
> col2:=COLOR(RGB,150/255,150/255,150/255):
> kvg0:=plots[implicitplot3d](kv,x=-13..13,y=-9..9,z=-6..6,grid=[30,30,30],style=patchcontour,color=red,lightmodel=light1,scaling=constrained):
> kvg:=plots[implicitplot3d](kv,x=-13..13,y=-9..9,z=-6..6,axes=frame,color=COLOR(RGB,250/255,250/255,250/255),style=patchcontour,grid=[30,30,40],light=[90,-5,1,1,1],tickmarks=[3,3,3],orientation=[52,63],scaling=constrained):
> PrumerR2g:=implicitplot3d(PrumerR2,x=-13..13,y=-9..9,z=-6..6,grid=[10,10,10],thickness=2,style=wireframe,gridstyle=rectangular,color=col2):
> Smer2g:=plottools[arrow]([-5, -5, 8], vector(6*Smer2), 0.5, 1, 0.2, cylindrical_arrow,color=col2):
> ug2:=plots[arrow]([-5, -5, 10], vector(Smer2), width=[0.2, relative],length=5, head_length=[0.2, relative], color=blue):
> Kuz1g:=spacecurve(Kuz1,x=-15..15,thickness=3,numpoints=1000,color=yellow):
Kuz2g:=spacecurve(Kuz2,x=-15..15,thickness=3,numpoints=1000,color=yellow):
> display(kvg,PrumerR2g,Smer2g,Kuz1g,Kuz2g,axes=frame,scaling=constrained);
```

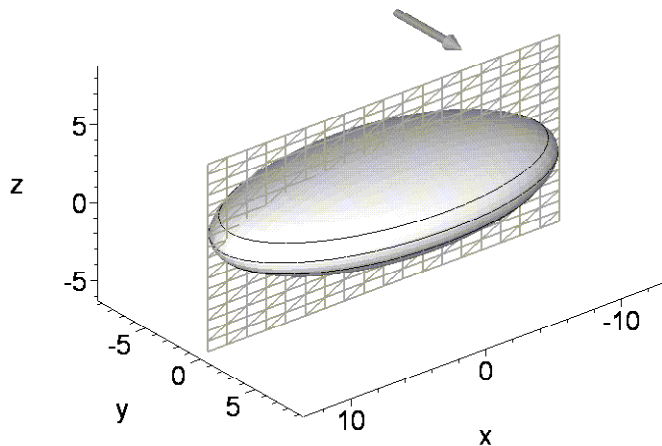

```
> Smer3:=eval(hs3,w=1);
```

```
Smer3 := [0, 0, 1]
```

```
> PrumerR3:=eval(PrumerR,[u=Smer3[1],v=Smer3[2],w=Smer3[3]]);
```

```
PrumerR3 := 16 z = 0
```

```
> kv;
```

```
 $x^2 + 4 y^2 + 16 z^2 - 144 = 0$ 
```

```
> {kv,PrumerR3};
```

```
{ 16 z = 0,  $x^2 + 4 y^2 + 16 z^2 - 144 = 0$ }
```

```
> res3:=solve({kv,PrumerR3},{x,y,z});
```

```
res3 := {x = 2 RootOf( $_Z^2 + y^2 - 36$ , label =  $_L4$ ), y = y, z = 0}
```

```
> Kuz:=allvalues(res3);
```

```
Kuz := {x =  $2\sqrt{36 - y^2}$ , y = y, z = 0}, {x =  $-2\sqrt{36 - y^2}$ , y = y, z = 0}
```

```
> Kuz1:=eval([x,y,z],Kuz[1]); Kuz2:=eval([x,y,z],Kuz[2]);
```

```
Kuz1 := [ $2\sqrt{36 - y^2}$ , y, 0]
```

```
Kuz2 := [ $-2\sqrt{36 - y^2}$ , y, 0]
```

```
> col3:=COLOR(RGB,100/255,100/255,100/255):
```

```
> kvg0:=plots[implicitplot3d](kv,x=-13..13,y=-9..9,z=-6..6,grid=[30,30,30],style=patchcontour,color=red,lightmodel=light1,scaling=constrained):
```

```
> kvg:=plots[implicitplot3d](kv,x=-13..13,y=-9..9,z=-6..6,axes=fra
```

```

me,color=COLOR(RED,255/255,255/255,255/255),style=patchcontour,grid=[30,30,40],light=[90,-5,1,1,1],tickmarks=[3,3,3],orientation=[52,63],scaling=constrained):
> PrumerR3g:=implicitplot3d(PrumerR3,x=-13..13,y=-9..9,z=-6..6,grid=[10,10,10],thickness=2,gridstyle=rectangular,style=wireframe,color=col3):
> Smer3g:=plottools[arrow]([-5, -5, 8], vector(6*Smer3), 0.5, 1, 0.2, cylindrical_arrow,color=col3):
> ug3:=plots[arrow]([-5, -5, 10], vector(Smer3), width=[0.2, relative],length=5, head_length=[0.2, relative], color=violet):
> Kuz1g:=spacecurve(Kuz1,x=-15..15,thickness=3,numpoints=1000,color=yellow):
Kuz2g:=spacecurve(Kuz2,x=-15..15,thickness=3,numpoints=1000,color=yellow):
> display(kvg,PrumerR3g,Smer3g,Kuz1g,Kuz2g,axes=frame,scaling=constrained);

```

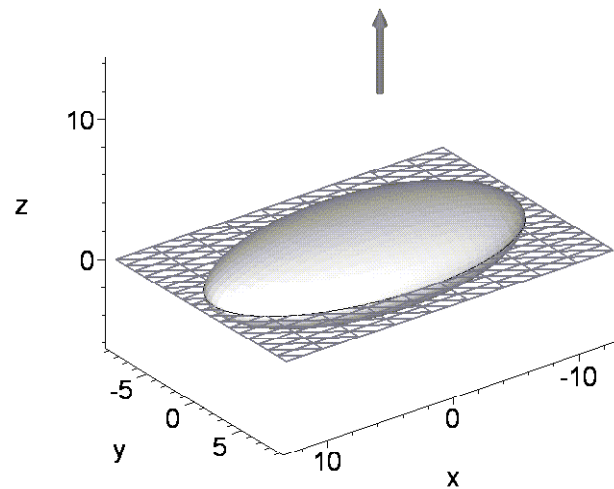

```

> display(kvg,PrumerR1g,Smer1g,PrumerR2g,Smer2g,PrumerR3g,Smer3g,Kuz1g,Kuz2g,axes=frame,scaling=constrained,orientation=[58,44]);

```

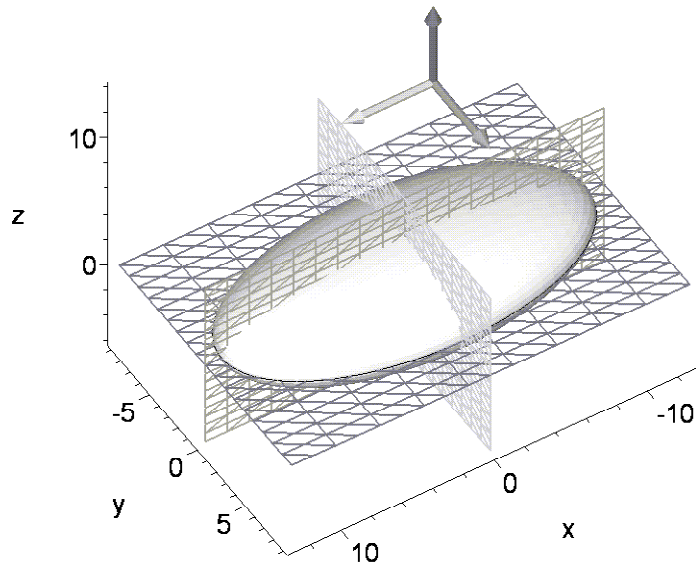

[>
[>